

# **EPC-760**

## **USER'S MANUAL**

**BSS Audio Ltd.**  
**HERTS ENGLAND**

This manual is provided to assist sound engineers, installers and consultants to fully understand the EPC-760, and to benefit from its full capability.

The information is structured under a series of broad headings for easy access. So where possible within each section:

- \* The most immediate information appears at the head of each section under the main title.
- \* As you read further into each subsequent section, more detailed, specific information is given.

Should you have any comments or questions about applying the EPC-760 within your application please write to us at the address in the warranty section.

---

TABLE OF CONTENTS

Title	Page	Title	Page
1. FEATURES & FACILITIES	3	11. SPARES	23
2. UNPACKING	4	12. SPECIFICATIONS	24
3. MECHANICAL INSTALLATION	5	13. WARRANTY	25
4. MAINS POWER	5		
Powering up			
Safety earthing			
AC power fusing			
Voltage setting			
Mains cable			
5. AUDIO CONNECTIONS	10		
6. CONTROLS	12		
Muting			
Polarity			
Sensitivity setting			
Attenuation setting			
Signal metering			
7. OUTPUT CONNECTIONS	15		
Damping Factor			
4/2 ohm load setting			
Bridge Mode			
Long speaker lines			
70 & 100v lines			
8. THE COOLING SYSTEM	18		
Filter inspection			
Temperature metering			
9. FAULT MODES	20		
10. OPTIONS	23		

## 1. FEATURES & FACILITIES

The EPC-760 is a highly efficient, compact and rugged high power amplifier, incorporating many of the sophisticated features of the widely acclaimed EPC-780. It anticipates the requirements of professional sound reinforcement in the 1990's, for both touring and fixed installations. Being designed with audio quality ranking equal first alongside utility and ruggedness, the EPC-760 is equally suited to recording studio monitoring.

- \* Two independently controlled channels in a compact 2U enclosure weighing only 16kg
- \* High Continuous<sup>1</sup> power, in excess of 650w per channel into 4 or 2 ohms<sup>2</sup>, or in excess of 1300w bridged into 8 ohms or 4 ohms<sup>3</sup>.
- \* Electronically balanced inputs, with optional high grade 10k transformer for fully floating specifications.
- \* Choice of 8 calibrated input sensitivities, selectable on the rear panel for security. Continuous control front panel attenuators with separate mute switch, for convenience.
- \* LED bargraph meter displays real-time signal output headroom.
- \* LED bargraph meter displays real-time temperature headroom.
- \* High slew limit output section offers reduced intermodulation at the amp-speaker interface and improved sonics at all frequencies.
- \* Very high damping factor, >1500 below 1kHz
- \* Automatic selection for mains supply voltage of 100-120v or 220-240v AC, and 6% power taps for full power output, plus wide safety margins coupled with under and over-voltage protection.
- \* Low power mains switching, with intelligent start-up and shut-down routines and fault diagnostics.
- \* Front-panel accessible filter for improved dust collection.

-----  
<sup>1</sup>FTC rating in USA

<sup>2</sup>With Load switch set for 2 ohms.

<sup>3</sup>With load switch set for 2 ohms

- \* Super efficient custom aluminium alloy heat-exchangers.
  
- \* 95% efficient electronic power supply reduces dissipation and coupled with a serial air flow management system helps keep internal temperatures low, reducing stress on all component parts and increasing their average lifespan.
  
- \* Consistent reliability and in-situ access to all main components including power devices gives easy serviceability through solid practical engineering.

---

## 2. UNPACKING

As part of BSS AUDIO LTD's policy of quality control, this product is carefully checked before packing to ensure flawless appearance, and that it reaches you in first class condition.

After unpacking the unit, please inspect for any physical damage and retain the shipping carton and all relevant packing materials for use, should the unit need returning.

With the EPC-760 will be a small packet of spare fuses. Please keep them in a safe place. A spare fan filter can be found behind the right hand side fan louvre.

If any damage has occurred, please notify your dealer immediately, so that a written claim for damages can be initiated. See the Warranty section of this manual.

---

### 3. MECHANICAL INSTALLATION

A vertical rack space of 2U (3½", 89mm) is required. The rear of the EPC-760 includes fixing holes for rear support when mounted into a rack and these must be used. Failure to do so will impare reliability and invalidate the Warranty. Figure 1 details the relevant dimensions and fixing centres. Weight is evenly distributed within the amplifier and the centre of gravity is therefore central.

Adequate ventilation is essential both at the rear of the rack, and also at the front, if enclosed by a cover or door. If the venting is inadequate, the EPC-760's temperature meter will give clear warning but thermal shutdown during periods of heavy use may mar the performance and ultimately reduce reliability.

If other makes of fan-cooled amplifier are installed in the same rack or cabinet, ensure that their airflow is front-to-rear, ie. in the same direction. Equipment with rear-to-front airflow should always be mounted in a separate rack if possible. Should this not be feasible, the EPC-760s should be kept apart and mounted below. Operating temperatures should be initially monitored, to check for adequate cooling.

**CAUTION:** Air emerging from the EPC-760's high efficiency heat-exchangers can reach 60 - 70 degC. To prevent personal injury or fire, please ensure that people and combustible or flammable materials (eg.newspaper, clothing, costumes, solvents etc, etc) are kept at least 2'0.6m from the amplifier's exhaust outlets. If venting is inadequate, the hot air can adversely affect other equipment, and may soften some thermoplastic enclosures. If using plastic coated cables, take care to dress the leads away from the airflow. Professional-grade rubber cables are not affected.

---

### 4. MAINS POWER

The power cord attached to this unit carries the following information label.

**WARNING ! THIS APPLIANCE MUST BE EARTHED.**

**IMPORTANT:** The wires in this mains lead are colour coded in accordance with the following code.

Green-and-yellow	: Earth
Blue	: Neutral
Brown	: Live

As the colours of the wires in the mains lead of this appliance may not correspond with the coloured markings identifying the terminals in your plug, proceed as follows:

The wire which is coloured green-and-yellow must be connected to the terminal in the plug which is marked with the letter 'E' or by the earth symbol which is '⏏', or coloured green and green-and-yellow.

The wire which is coloured blue must be connected to the terminal which is marked with the letter 'N' or coloured black.

The wire which is coloured brown must be connected to the terminal which is marked with the letter 'L' or coloured red.

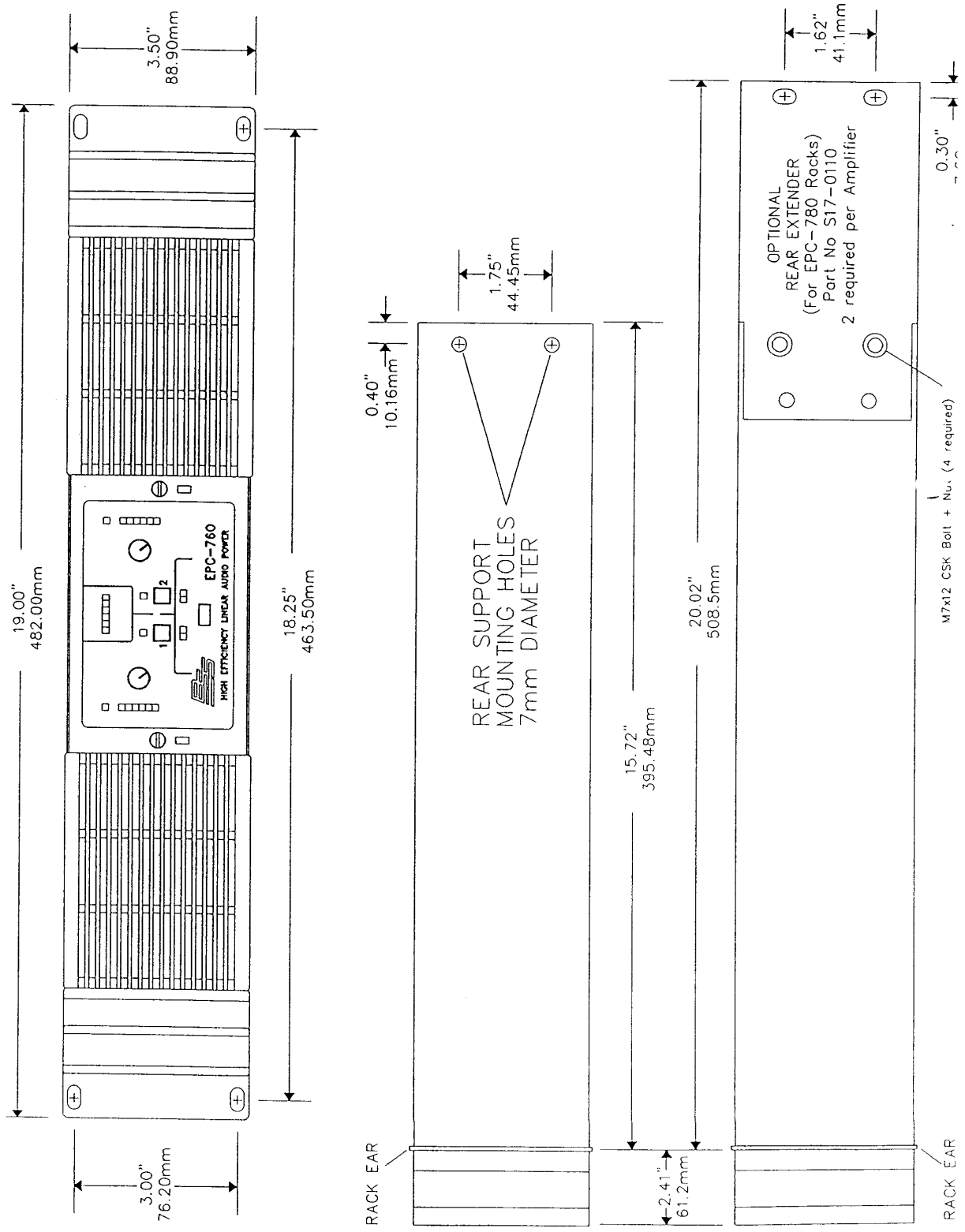
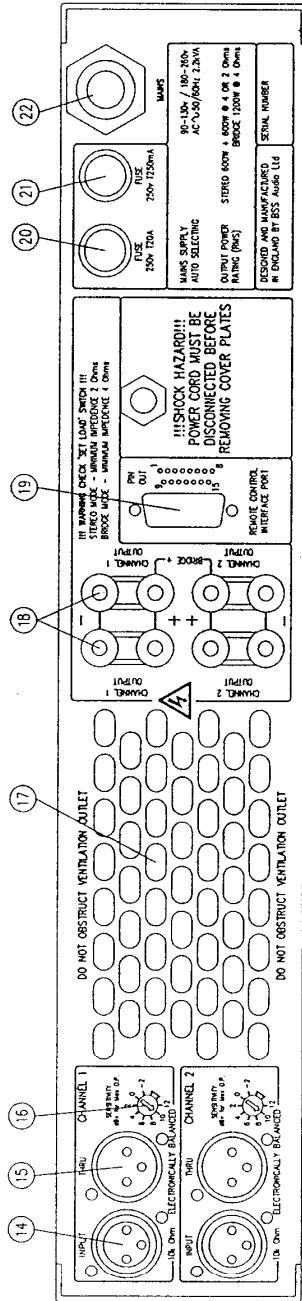

FIGURE 1. MECHANICAL DIMENSIONS



- 1. REMOVABLE FAN GRILLS
- 2. THUMB SCREWS
- 3. FAULT INDICATOR
- 4. SIGNAL OUTPUT LEVEL METER
- 5. SIGNAL ATTENUATOR CONTROL
- 6. TEMPERATURE METER
- 7. CHN. MUTE INDICATOR
- 8. CHN. MUTE SWITCH
- 9. LOAD SETTING SWITCH
- 10. LOAD SETTING INDICATOR
- 11. MAINS POWER SWITCH
- 12. ESCUTCHEON PLATE
- 13. BRIDGE MODE SELECTOR SWITCH
- 14. SIGNAL INPUT XLR
- 15. SIGNAL THRU XLR
- 16. SENSITIVITY SELECTOR SWITCH
- 17. HOT AIR EXHAUST VENT
- 18. SPEAKER CONNECTION TERMINALS
- 19. REMOTE CONNECTOR (NOT IMPLEMENTED)
- 20. MAIN POWER SUPPLY FUSE
- 21. AUX POWER SUPPLY FUSE
- 22. POWER CORD

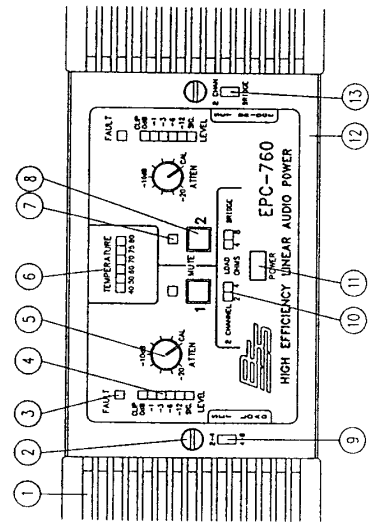

FIGURE 2. FRONT AND REAR PANEL FACILITIES



The EPC-760 operates from any international 50/60Hz AC mains supply between 108v and 240v <sup>±</sup> without adjustment. Setting is automatic. Simply plug the unit in.

The EPC-760's rated power output is achieved at any nominal international supply voltage. However, if the supply voltage falls or rises to a significantly different voltage after powering-up, the EPC-760 will experience exactly the same voltage/power variation as a conventional amplifier with hard-wired taps.

#### Powering Up

Both channels are switched on or off by depressing the grey 'POWER' button. After 15 to 30 seconds, the channel's mute LED will extinguish and at the same time, the amplifier partially un-mutes, ie. passes a low level signal. This low level lasts for 2 to 4 seconds, after which the output level rises to it's full level, dependent on the input attenuator and sensitivity control settings, in the normal way. The pause allows time to (re) mute the channel to silence the outputs if desired.

#### Safety Earthing

The Green/Yellow wire on the EPC-760's mains cord must always be connected to the electrical installation's safety Earth or Ground. It is essential for personal safety as well as proper operation of the unit and is internally connected to all exposed metal surfaces. Any rack into which this unit is mounted is assumed to be connected to the same grounding circuit. The EPC-760 has electronically balanced audio inputs and does not need disconnection of the safety earth for the avoidance of hum loops.

#### AC Power Fusing

The incoming mains power feeds two separate power supplies, with fuses located on the rear panel. If they need replacing they must be replaced with those of the correct value. It is most important for continued safety that this is adhered to. Spare fuses are supplied with the unit. The fuse ratings are:

Auxiliary: T250mA, 250v, 20mm.

Main: T20A, 250v, 1¼", Ceramic. (such as Bussman ABC)

Should one or more fuses blow, make a single replacement after checking for and eliminating any obvious causes. Should the replacement fuse blow, please contact BSS AUDIO LTD or your local dealer.

It is most important that the high current 20A fuse is replaced with one of the correct specification, such as that supplied with the amplifier.

#### Mains Voltage Setting

At switch-on, the EPC-760 pauses to 'read' the average mains voltage and sets itself accordingly. Thus strain on the amplifier's components are reduced, as are variations in power output.

In use, should the AC supply voltage exceed safe limits, the amplifier powers

-----  
±108 to 121v (USA, Canada, Japan)  
214 to 240v (UK, Europe, Australia)

down instantly. The over-voltage needed to trigger shut-down is at least 18% above the nominal.

**WARNING !** If the sound system supply is derived from a Variac (variable transformer), the EPC-760 should be switched on after the Variac has been set to the desired voltage, ie. do not 'wind-up' the voltage with the EPC-760 switched on. Connection to self-adjusting ('constant voltage') Variac supplies is unnecessary and may cause malfunction.

#### Mains Voltage Range

The minimum mains supply voltage for which the amplifier will operate is: 180v for 220/240v range, and 90v for the 108/120v range. However power output will be reduced accordingly from the minimum full-power values.

The maximum supply voltage which exceeds safe limits and causes the unit to switch-off is in excess of 260v for 220/240v range, and 130v for the 108/120v range. This is however dependent on load impedance and program drive level as mentioned above. Obviously, the mains voltage will reach these limits only in exceptional circumstances and the FAULT LED will then flash.

When the FAULT LED flashes, the EPC-760 is powered down and latched off. If the amplifier is switched OFF, then ON again, it will work normally if the fault was only temporary (a 'glitch'). Should the fault persist, it will power down again.

#### Current Consumption and Mains Cabling

In common with other high power amplifiers, the EPC-760 can demand high peak currents off the AC supply. Due to it's high efficiency and advanced power supply design, peak current draw is small considering it can produce 1.5kW of audio power. Even so, should the cable's resistance be too high, the supply voltage's peak value at the amplifier can easily be 5 to 30 volts low, even though the cables are running cool. To minimise supply resistance, and for electrical safety, a heavy gauge 4mm<sup>2</sup> cable is fitted.

It is essential to use the correct gauge of cabling for the incoming mains supply.

Where a single EPC-760 is used, it should be directly connected to an adjacent 13 Amp or equivalent ring main outlet (If in doubt, users should consult a qualified electrician).

For optimum performance in multiple amplifier installations, it is probable that groups of amplifiers will be distributed across a three phase supply and this should only be attempted by qualified electricians. As a rough guide, the maximum current demands for each EPC-760 are given below, however this will depend largely on the speaker load impedance and the nature of the program material.

Allow 8 amps per amplifier for 220/240v operation.

Allow 16 amps per amplifier for 108/120v operation.

These are repetitive sinewave values referred to full drive. The average current draw for typical music is always lower, usually half as much.

Should a single power cable be used to connect racks containing two or more amplifiers it should be rated in proportion. To illustrate this, table 1 gives

the conductor's minimum recommended cross-sectional area for a fixed installation, with cable bunched in conduit. We recommend that cable size is increased substantially for lengths over 20 feet/7m.

Table 1.

No EPC-760 <sup>1</sup>	Cable size in mm <sup>2</sup>	
	108/120v	220/240v
2	6mm	2.5mm
4	10mm	6mm
6	16mm	10mm
8	25mm	16mm
10	use 2x25mm	25mm
Above 10, use parallel cables to increase current rating pro rata. Consult a qualified electrician,		

The table presumes worst case conditions, ie. hard drive with compressed or band-limited programme. For more information on current draw, see the specification.

## 5. AUDIO CONNECTIONS

### Input Connections.

The EPC-760's inputs are 10k ohm electronically balanced and will be 'fuss free', regardless of the installation's complexity providing a sensible grounding system is utilised. For those applications where transformer balancing is required this is available as a standard option. Figure 3 shows the connector wiring.

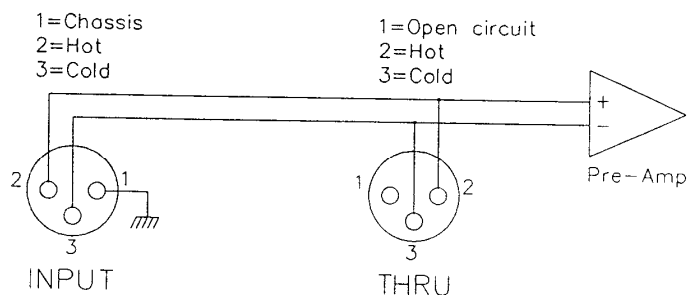

FIGURE 3. CONNECTOR WIRING.

Balanced signal sources to the amplifier should be connected to the female 3 pin XLR labelled INPUT. Pins 2 and 3 of the male 'THRU' XLR are wired in parallel with the input to give a link output for daisy chaining. It is recommended that you use high quality audio cable with 2 cores + screen.

<sup>1</sup>Or other amplifiers of similar power rating and efficiency.

For unbalanced wiring it is recommended that similar 2 core + screen cable is used with the cold or out-of-phase terminal being connected to the unbalanced source's ground. The connecting cable must be screened from the EPC-760 pin 1 connection and should not be connected to the unbalanced equipment's ground, where it must be tied back and insulated.

The shield connection to pin 1 at each EPC-760 input must be maintained under all circumstances, as BSS AUDIO LTD will not be responsible for consequential damage arising to loudspeakers, etc. should this connection not be made.

#### Daisy-Chaining

If both channels of the EPC-760 are required to be driven by the same input signal, use the THRU output XLR socket on the driven channel to link across to the INPUT XLR of the other channel. On more complex installations it is preferable to arrange daisy-chaining (linking) externally on a patch-panel, where space allows for better access.

Each amplifier input has an input impedance of 13k ohm, seen between pins 2 & 3 of the XLR. This allows a maximum of sixteen amplifier channels to be daisy-chained (parallel connected) at their inputs, when driven from a standard pro-audio output, ie. one capable of driving 600 ohms, usually up to +18dBu (6v) or greater. All BSS AUDIO LTD products meet this specification.

When a long cable is used (eg. above 10m/30'), the maximum number of channels should be reduced on HF and FULL-RANGE feeds - as the cable's capacitance will also load the source at high frequencies. The number of daisy-chained LF and MF sources is not affected by cable length.

For very large installations where it is necessary to daisy-chain more than sixteen (16) amplifier channels, local distribution amplifiers should be used, such as the BSS AUDIO LTD MCS Line Drivers.

It is also possible to reconfigure the THRU output XLR connector of the amplifier to provide an unbalanced buffered output for daisy-chaining. With this approach, there is no limit to the number of amplifier inputs that can be driven, as each interconnection sees only one input load.

## 6. CONTROLS

### Muting

Simply depress the mute button to instantly 'kill' the output. Depress again to un-mute. The signal will be reinstated at a reduced level. After 2 to 4 seconds, the drive level will revert to normal as governed by the sensitivity and attenuator setting. The pause gives you 'thinking time'.

Muting is automatic at power-up and power-down and also if a fault is detected.

### Polarity

When EPC-760s are used in conjunction with other types of power amplifier, make sure the output polarity is consistent by verifying the connections, or by testing for uniformity with a given polarity of input signal. Remember, in multiple speaker stacks, clusters or arrays, incorrect loudspeaker polarity can upset coverage and create spurious imbalance, 'phasiness' and colouration.

Incorrect polarity can be put right by one of the following, whichever is most expedient. Before you start, make sure that the polarity error is caused by incompatibility between amplifiers being driven in the same frequency band. If the polarity problem is solely between different frequency bands, it is much easier to correct the problem at the (active) crossover, using the polarity ('Phase Reversal') switch. Be sure to mark any "ad hoc" connections or reversals to avoid future confusion:

i) Change round the connections to the amplifier's input pins. For an XLR, transpose the connections to pins 2+3. This procedure only applies to balanced inputs, as fitted to the EPC-760 and many other (but by no means all) makes of amplifier.

ii) Change round the + & - output connections at the amplifier. This approach assumes the speaker load is floating, as it must be in a proper installation. That is, it is not connected to anything else such as earth or ground. If the load is not floating return currents through the system ground may seriously affect other equipment and BSS accepts no responsibility for damage so caused.

iii) Change round the + & - connections at the speaker(s).

In accordance with international standards <sup>1</sup>, EPC-760's are supplied with Pin 2 hot (+), so a positive (+v) input gives a positive (+v) output from the red (+) output terminals.

The EPC-760 can be converted to become 'pin 3 hot' if desired, although this convention is now generally obsolescent. This is sensible however if it forms part of a system or installation where the 'pin 3 hot' convention has already been adopted.

### Sensitivity

The EPC-760's nominal input drive for full power can be varied between -2dBv and + 12dBv by the rear panel sensitivity switch. A front panel attenuator control is provided to allow the maximum output power to be backed-off.

<sup>1</sup>IEC Doc.427 (XLRs)

In common with other high power amplifiers, the input sensitivity is defined as the drive level needed to produce an output that is just below clip (overload or 0dB) - where maximum undistorted power is developed. The exact input sensitivity varies depending on operating conditions, because the overload point to which it is referred hinges on drive level, programme density, the speaker impedance, and supply voltage. (For example, during loud passages, and especially when driving low impedances, a multi-kilowatt array of amplifiers can demand high enough currents to cause the supply voltage to sag, thus changing the point at which clipping occurs).

To overcome the uncertainty caused by these variations, the EPC-760's signal metering is referred to the output, giving a true indication of output headroom in real-time.

#### Attenuation & Gain Setting

Each channel's sensitivity can be adjusted with the stepped attenuators, located on the rear panel. The eight preset positions marked -2 to +12dB in steps of 2dB, ensure accurate ganging between units. The settings generally correspond with sensitivity in dBv provided the front panel attenuators are set at CAL, ie. the +12dB setting yields a +12dBv sensitivity.

When setting up a system, always make sure that the front-panel attenuation controls are set at CAL before adjusting the rear-panel attenuators.

The front-panel attenuation controls have a different function. They reduce the output drive, but have no effect on input headroom.

**WARNING !.** When they are backed off, do not try driving the EPC-760 harder in order to compensate. This is misuse !

The front panel attenuation controls are useful when you need to bring a level up slowly (as required for tentative testing). They may also be used to restrict the power output to a specific channel (say), provided the input drive is already fixed at a suitable level, ie. not overloading when the front panel controls were set at CAL. When set at -10 and -20dB, the EPC-760's power output is reduced by ten and a hundred times respectively.

In studio monitoring systems with high headroom, power amplifier attenuators are often backed-off to reduce hiss. The EPC-760's gain structure is configured so the residual output hiss is practically inaudible, even with high efficiency PA speakers. If the incoming lines from the (active) crossover are noisy, we recommend you first try adjusting the system's gain structure. If hiss remains obtrusive, then reduce the stepped attenuators on the EPC-760's rear panel. If you attempt to drive the amplifier at full power with significant front-panel attenuation applied, distortion may result !

The following table gives the overall gain of the amplifier from the input connectors to the output terminals, for each position of the SENSITIVITY selector and the SET LOAD switch.

**CAUTION !** In BRIDGE mode the gain will be +6dB or (x2) higher.

SENSITIVITY SETTING dBv	4 OHM 2 CHN		2 OHM 2 CHN	
	(dB) gain (x)		(dB) gain (x)	
-2	39	89.13	35.3	58.20
0	37	70.79	33.3	46.23
+2	35	56.23	31.3	36.72
4	33	44.67	29.3	29.17
6	31	35.48	27.3	23.17
8	29	28.18	25.3	18.40
10	27	22.39	23.3	14.62
+12	25	17.78	21.3	11.61

The following table gives the available single channel output voltage (RMS) before clip into the nominal load and with nominal mains (240v)

**CAUTION !** The output voltage swing available in practice will vary according to mains voltage and load conditions, as described elsewhere in this manual.

MODE SET	V RMS	dBv
2 ch 4 ohm	55	37.0
2 ch 2 ohm	36	33.3
Bridge 8 ohm	110	43.0
Bridge 4 ohm	72	39.3

### Signal Metering

Each channel's drive level is displayed on a LED bargraph. The bottom (green) LED confirms the presence of an input signal, provided it's above -25dBv / 50 mV.

The top (red) LED illuminates 0.5dB below true clip, ie. irrespective of the load impedance or AC supply - both of which can influence the output clip threshold.

The metering responds in 5mS and holds for about half a second, so every audibly significant peak is visible.

As the metering is referred to output headroom instead of the absolute input level, take care when interpreting the readings.

**CAUTION !** Do not use the meters to align or calibrate external equipment. For example, if two adjacent channels are fed from the same line but are driving different speaker impedances, the meter readings will differ to reflect the extra loading on one channel, even if the input attenuator settings are identical.

## 7. OUTPUT CONNECTIONS.

Two pairs of 4mm terminals wired in parallel are provided for each channel. The RED terminals, marked '+' are 'live' and are in phase with pin 2 of the input connector. The BLACK terminals, marked '-' are at ground potential and are connected to the chassis and the mains earth within the amplifier.

It is essential that the loudspeaker wiring remains isolated from ground, or the system earth to prevent high signal currents returning to the amplifier by way of the mains earthing system, or worse via the input cable screen. Such currents will at the very least cause instability, oscillation and high levels of crosstalk, and if the system grounding is poor or faulty, may burn out wiring or damage equipment connected to the system.

It is however permissible to connect the output terminals to the 'sense' or 'monitor' terminals of loudspeaker managements systems or control processors providing they have been specifically designed to limit earth currents to a few hundreds of milliamps.

Each output terminal accepts a 4mm plug at the rear. Alternatively, bared conductors can be threaded. Even better, we recommend you crimp a Spade Lug or 'Bootlace' Ferrule to the conductor's end. For firm clamping, the conductors' cross-sectional area should range between 1.5mm<sup>2</sup> and 6mm<sup>2</sup>.

For most installations, the minimum recommended conductor size is 2.5mm<sup>2</sup>. But for optimum performance, see below.

In permanent installations, we recommend you tighten the plastic clamp with a broad screwdriver or coin, to prevent conductor tarnishing and preserve a reliable, low resistance connection. Installers should include checks on terminal tightness in periodic maintenance schedules.

### Damping Factor

The EPC-760's outputs provide an unusually high damping factor, typically 1500 times at low audio frequencies. The damping can help the amplifier control the loudspeaker driver-units, providing the resistance of the intervening cable(s) and connectors is very low. The sonic benefits of high damping factor are most pronounced at bass and low-midrange frequencies (ie. 10 to 600Hz).

Load damping is degraded by thin conductors &/or long output cable runs; by tarnished, corroded or loose connections, and by the resistance of passive crossover networks. Amplifier damping factor is not meaningful if two drive-units are connected in series.

Damping Factor is preserved by installing cables containing conductors with large cross-sectional areas, by specifying connectors with gas-tight contacts, and by using active systems (so an active crossover replaces passive networks). To avoid unnecessary loss of damping factor, avoid daisy-chained outputs, particularly to LF and MF drivers. When several cabinets or drivers are connected to one output, we recommend you make separate connections, to maximise damping factor with any given gauge of cable.

The EPC-760 accepts conductors up to 8mm<sup>2</sup>. Larger conductors (10 & 16mm<sup>2</sup>) may be required for critical recording monitoring. They can be terminated by tinning and paring, or by soldering to a 'Bootlace' (reducing) Ferrule.



To summarise, the sonic benefits of the EPC-760's high damping factor will not be fully realised if the output cable is too thin relative to its length and the impedance of the drive-units connected to it. The longer the cable, the thicker it needs to be to maintain a reasonably low resistance. Poor damping factor can impair bass depth and midrange resolution, and exacerbate dynamic interactions between the room and the drive units. For further advice, consult the loudspeaker maker.

#### Selecting Bridge mode and Load Impedance

The EPC-760 may be configured as two independent channels to deliver its full rated output into either 2 or 4 ohms, or it may be 'bridged' to provide a single high power channel into either 4 or 8 ohms. The amplifier is initially supplied set to '2 channel' mode and 4 ohms, but the mode settings should be checked and reset to the users requirements before it is switched on.

Switching of the load impedance setting is desirable because low impedance loads require less voltage and more current than high impedance loads and without an external adjustment an amplifier will need to compromise its performance across a range of loads.

In conventional amplifiers, the power output into impedances below 4 ohms is commonly either progressively limited (which can sound inferior), or else it attempts to double each time the load impedance is halved. Either way, low impedance loads pull high currents and can exert a great strain on the amplifier's output devices, the heat-exchangers and the power supply - particularly if the amplifier has been designed to drive high power into 8 or 16 ohm systems (ie. high voltage/low current).

#### Access and Setting

The mode switches are reached by undoing the two thumb screws and removing the escutcheon plate and filter covers. Take care not to fold or crush the white filter pads which are held inside the recess of the filter covers.

The right hand switch is labelled SET BRIDGE and should be set as required. If you are selecting bridged mono mode you will need to read the sections about bridge mode operation which follow.

The left hand switch is labelled SET LOAD and controls both channels of the EPC-760 together. It is not possible to have each channel set for a different load at the same time. The lower position marked '4--8', may be selected if the nominal speaker impedance is 4 ohms or higher, when in the 2 channel mode, or is 8 ohms or higher when in bridge mode. The upper position marked '2--4' will allow the amplifier to efficiently drive speakers with a minimum impedance of 2 or 4 ohms in 2 channel or bridge mode respectively.

**WARNING !** Setting of the SET LOAD and SET BRIDGE switches must be done with the amplifier switched off. Changing the settings with the amplifier turned on will have no immediate effect. However the EPC-760 will reset to the indicated mode when next powered up.

#### Front Panel Mode Indication

One of four mode LEDs just above the POWER ON switch will illuminate when power is on to indicate the combination of switch settings selected. From left to right these are '2 channel + 2 ohms'; '2 channels + 4 ohms'; 'bridge + 4 ohms'; and 'bridge + 8 ohms'.

The decision to use the 2-4 ohm setting need not be complicated. In practice, if the amplifier is driving less than 4 ohms, (or 8 ohms in bridge mode) or is driving a nominal 4 (8)ohms, but the temperature metering reads high, simply select the 2-4 ohm setting. If a 2 ohm load is driven with the 4 ohm setting, no harm will be caused, but you can expect high dissipation at high power levels, which may ultimately lead to amplifier shutdown.

#### Which speaker impedance?

In most active speaker systems, the nominal speaker impedance is close to the minimum value (with continuous signals) and rarely more than half the minimum under transient dynamic conditions. The EPC-760's normal 4 ohm rating refers to nominal impedance ratings, and already allows for short term worst case dips to around 2 ohms.

In systems employing passive crossovers, transient impedance dips can be one quarter of the rated nominal, possibly 1 ohm for a nominal 4 ohm system. In such instances, ie. when driving a loudspeaker model that is reputed to be 'hard to drive', the 2 ohm setting may give better sonic results and cooler running. It should certainly be evaluated if the amplifier overheats and cuts out, or appears to run hotter than anticipated.

#### Bridge Mode Input Configuration

In bridge mode both channels of the EPC-760 are reconfigured internally and driven from channel 1's input connector and pre-amplifier. The input connector and pre-amplifier for channel two is therefore disconnected. All connections and the sensitivity adjustment need only be made to channel 1, as described in section 6 of this manual.

#### Bridge Mode Output Wiring

Only the RED 'live' output terminals are used in bridge operation with the loudspeaker being connected across them. They are driven in anti-phase so that the total voltage swing available is twice that of one channel when used on its own. The red output terminals of channel 1 are the '+' or in phase with pin 2 of the input XLR, and the red output terminals of channel 2 are the '-' or out of phase. No connection should be made to the black terminals and it must be remembered that both wires and speaker terminals are live.

#### Bridge Mode Front Panel Controls

When in bridge mode only the Channel 1 ATTENUATOR is used to back off the output level, Channel 2's attenuator is disconnected and has no effect.

Both the MUTE buttons are connected together internally and pressing either one will toggle the mute. Likewise, both output meters will respond together and the protection circuits are cross coupled so that in a fault situation both output stages will close down together. However if a fault is detected in only one channel then only that channel's fault LED will blink, thus aiding diagnostics.

### Long Speaker Lines

Whenever loudspeakers are connected to power amplifiers by long cables (above 20'/6m), there is invariably an increased risk of high frequency instability. It is aggravated by the combination of RF pickup in unshielded cables (aerials !) and multiple, complex reactances in the cable and loudspeaker(s) and passive crossovers (where fitted).

High frequency instability can be avoided by adopting these common sense rules:

- i) Ensure the input wires are shielded and that the shield is connected to the EPC-760's input XLR pin 1.
- ii) Do not run output cables next to input signal lines. Keep apart, and preferably cross at right angles. If cables have to follow a similar route or path, keep them separated by at least 24"/0.6m.
- iii) Conventional speaker interconnections rely on flexible cables principally made for AC mains, in which the conductors lie parallel, ie. side-by-side. Superior interconnections can be made by using cables with twisted conductors. Twisting reduces the signal strength radiated from the cable, reduces noise and RF pickup from other adjacent high current conductors (eg. lighting power cables), and also reduces inductance per unit length, which enhances stability.

### 70/100 volt lines

The EPC-760 drives 70 and 100 volt lines directly. The nominal output voltage is 70v rms. The amplifier's built-in DC servo and protection circuitry means that DC blocking capacitors are not necessary, although these may be desirable to roll off low frequencies.

---

## 8. THE COOLING SYSTEM

The EPC-760 employs unique, highly efficient solid aluminium alloy heat exchangers for both the power supply and the audio amplifiers. They are cooled by a DC servo driven fan and thermally protected.

**WARNING !** Because the cover plates form part of the ducting which channels the air flow through the heat exchangers, the amplifier must never be used with them either removed, or loose.

Operating temperatures are monitored close to the power device junctions and are displayed on a LED bargraph meter, scaled in degC, on the front panel. Audio power drive is muted if the temperature rise exceeds the bargraph's scale, ie. at 86degC. Reset is automatic. Monitoring the output devices rather than the heatsink improves the thermal safety margins (it is the devices that will fail, not the heat exchanger). This also means that the temperature meter will show fairly rapid temperature changes, ie 10 to 15degC between quiet and loud passages of program material. These rapid temperature fluctuations are common to all conventional power amplifiers and should not cause concern.

Incoming air is drawn through the left hand filter louvre visible on the front panel. The right hand filter louvre plays no part in the cooling system. A spare

filter is supplied with each amplifier behind the right hand side louvre, and they are also available separately.

#### Filter Inspection & Maintenance

The filter pads are easily inspected by unscrewing the prominent thumb screws and removing the plastic louvres. The electret filter media is located on the inside of the louvre.

**WARNING !.** To avoid dirt entering the amplifier when inspecting or changing the filter pads, switch the amplifier off. Do not allow dust to be sucked into the vent and observe safety rules by removing jewellery. Never poke metal objects into the air inlet aperture.

Keep the filters clean and do not operate the amplifier without the filters in place, except in an emergency. In common with ordinary heatsinks, heat dissipation can be seriously impaired by a covering of dust. If the dust build-up inside is substantial, it may prove impossible to remove except with specialist cleaning equipment.

Inspect the filter pads periodically, or whenever the amplifier's temperature metering indicates a higher than normal operating temperature.

Whether inspecting, cleaning or fitting, take care not to fold or crush the filter material, and on replacing ensure that the filter covers the full area of the grill with no gaps at the edges which will let air and dust bypass the filter element. Although the filter elements may be cleaned by shaking them or washing in a mild detergent, this is only advisable in emergencies. NEVER refit wet or damp filters.

If the air supply is unusually dusty (eg. Outdoors &/or industrial environments), you may decide to pre-filter it to prevent the individual pads clogging prematurely. Pre-filtering is normally fitted to a sealed rack system into which the EPC-760s would be installed. Suitable high-capacity filters and racking systems are available from a variety of industrial sources.

#### Temperature Metering & Protection

The front panel LED bargraph monitors the 'real' temperature of the output devices close to their junctions. Each channel's output is muted if the temperature exceeds 86 degC. If this happens the FAULT LED will flash, but unlike other fault modes, the MUTE LED will also be lit and latched, ie. pressing the mute button has no effect.

Reset is automatic once the temperature has fallen to around 60 degC. During this time the fan continues running at full speed to reduce the temperature as quickly as possible. However owing to the heatsink's very high thermal capacity, it is normal for the cooling-down (hence reset) to take a few minutes.

If over-heating occurs, it is worthwhile checking:

- i) The load impedance. If you are driving a speaker with an impedance of 4 ohms or below, see Output Connections, section 6.
- ii) The drive level. Is the amplifier regularly being driven into hard clip ?
- iii) The filter(s), see the above section.

iv) The rack airflow.

Once the 'top' LED marked 80 degC has lit, there is no further warning that thermal cutout is imminent, although it will happen at a slightly higher temperature. For this reason, when operating a 'live' system, we recommend you take immediate steps to reduce or slow the temperature rise (eg. back-off the drive level by a few dB), before the 80 degC LED lights.

---

## 9. FAULT MODES

The EPC-760 has been built for rugged hard work and will cope with strenuous, demanding situations. It has also however been designed to 'intelligently' monitor it's internal workings and operating conditions and protect itself and the load from potentially damaging circumstances. The unit is protected against DC on the output, instability, over voltage and over current.

When a protection circuit is activated one or both of the front panel FAULT LEDs will flash. If only one LED flashes, it indicates the problem originates in that particular channel. If both LEDs flash it suggests that the problem has been detected in circuitry common to both channels, probably the power supply. Some fault conditions will cause the EPC-760 to instantly shut down and remain off (LATCHED FAULT MODE). Others will cause the PSU to shut down briefly but then automatically recycle and reinstate power (RE-ENTRANT FAULT MODE). If a fault persists, or another fault is detected during re-entrant fault mode then the amplifier will go straight into latched fault mode and remain off.

### Resetting The Latched Fault Mode.

Before resetting from the latched fault mode some attempt should be made to find and rectify the cause of the malfunction by referring to the next section. The amplifier is reset by turning the POWER off, waiting a second or so, and then turning the POWER back on again. Note however that if the fault was due to the output current exceeding its allowed maximum (approx 75 amps) due to a short circuit on the output terminals then the amplifier must be left turned off for a period of about 20 secs before the power is re-applied.

The various combinations of fault symptoms are given below with a description of the possible causes. These are listed in order, with the most likely reasons mentioned first. It is only rarely that a flashing fault LED indicates an internal failure. More commonly the amplifier is responding to conditions which, should they persist, are likely to cause damage. Note that whenever one or both fault LEDs are flashing both MUTE LEDs will light and the mute buttons will be inoperative. This is quite normal.

### Both fault LEDs flash and temperature reads full scale.

**THERMAL SHUTDOWN:** The amplifier is overheating. During thermal cycling the fan continues to operate at full speed. When the temperature has dropped to about 60 degC the fault LEDs will stop flashing, the mutes will release, and normal operation will be resumed. Check that the air filter is not clogged and that airflow is not restricted.

Both fault LEDs flash continuously. Mute LEDs latched on.

LATCHED FAULT: A fault common to both channels has latched the power supply off. The fan will also be inoperative. See also the Re-entrant fault section as these may latch if persistent.

1) Short circuit between channel 1 and channel 2 output terminals. This is more likely to occur when in bridge mode. Note that the amplifier will need to be powered down for at least twenty seconds, before it will reset.

2) Mains 'brown-out' or 'drop-out'. The power supply is very tolerant to mains voltage fluctuations but when it does fall below 60% of the selected range for more than a few hundred milliseconds, it will turn off to prevent malfunction. Ensure that the mains supply voltage is correct and steady before resetting.

3) Mains 'over voltage' or extended surge. If the mains voltage should rise by more than 20% from its value at the time of switch on, the power supply shuts down to prevent malfunction. The incoming mains supply is very well filtered and surge suppressed and mains spikes are seldom a problem. Ensure the mains voltage is correct and steady before resetting.

4) Component failure. If after checking the above, the latched fault indication persists and cannot be reset by switching power off and on again, refer to your dealer for service.

One fault LED flashes continuously. Mute LEDs latched on.

LATCHED FAULT. A fault in the indicated channel has latched the power supply off. the fan will also be inoperative. See also the re-entrant fault section as these may latch, if persistent.

5) Short circuit at the channel's output terminals. Note that the amplifier will need to be powered down for at least twenty seconds before it will reset.

6) Excessive HF or RF interference pick up on the input cable. the EPC-760 has a very high CMRR and HF filtering, but extreme interference can still 'swamp' the input stage and break-through to subsequent circuits. Check the integrity of input lead screens and keep them clear of scaffolding or lighting trusses that are not properly ground strapped.

7) Component failure. If after checking the above the latched fault indication persists, and cannot be reset by switching the power off and on again, refer to your dealer for service.

Both fault LEDs flash for 3 seconds, then operation resumes.

RE-ENTRANT FAULT. A transient condition has been detected which exceeds the 'design envelope' of the amplifier. The power supply has shut down briefly to protect itself, then automatically gone into its power-up sequence.

**WARNING!** Switch off if the re-entrant fault mode cycles continuously. If the fault cannot be traced refer to your dealer for service.

8) PSU Over-Current. When the instantaneous power demand from the power supply reaches about 6500W, it closes down instantly. Although most of the peak current requirements of the output stage are met by the secondary reservoir capacitors, severe clipping at low frequencies combined with demanding loads can cause this value to be exceeded. Check the load impedance, and/or reduce the

input signal drive level.

9) Intermittent mains or mains wiring. Check that the amplifier is not going through its normal switch off/start up sequence due to mains drop-outs.

10) Burst HF interference. Check as in fault 6 above.

11) Component failure. If no external cause can be found and the problem persists, refer to your dealer for service.

One fault LED flashes for 3 seconds, then operation resumes.

RE-ENTRANT FAULT. A transient condition has been detected in the indicated channel, which may harm the amplifier or the loudspeaker. The power supply has shut down briefly and then automatically powered up.

**WARNING!** Switch off if the re-entrant fault mode cycles continuously. If the fault cannot be traced refer to your dealer for service.

12) Excessive HF present in the input signal. Clipping bursts of signal above about 10kHz, or bursts of power in the region of 25kHz to 100kHz will trip the protection circuits. Check the input wiring and its grounding, and the source equipment for instability. Check as in section 6) above.

13) Component failure. If no external cause can be found and the problem persists, refer to your dealer for service.

## 11. OPTIONS

### Fitting input balancing transformers.

Space is available internally to fit a high quality 10k ohm balancing transformer for each input. The necessary parts are provided as a kit from BSS AUDIO however, once fitted, it will be necessary to trim the input CMRR again and as such it will be preferable to allow your dealer to install the transformers and carry out the recommended alignment procedure.

---

## 12. SPARE PARTS ORDERING.

Should you require to order replacement parts for your EPC-760, please be sure to quote the model number and serial number as well as the BSS part number shown below. This will greatly assist our sales staff and ensure you receive the correct parts.

DESCRIPTION	BSS PART.	DESCRIPTION	BSS PART
Fan filter	X02-0010	Fan grill	S09-0010
Main fuse 20A	M03-0010	Control knob	N01-0090
Aux fuse T250mA	M01-0025	Control knob cap	N03-0065
Thumb Screw	W03-0070	Mains switch	K03-0065
Cover plate screw	W03-0015	Mute switch	K03-0010
Spk terminal-red	L05-0130	Spk terminal-black	L05-0135
Device spring clip	W13-0060		

**WARNING!!** The output devices in the audio amplifier stages are specially selected to ensure equal sharing of dissipation. Should it be necessary to replace these it is essential that replacement devices fall into the correct selection category. Please refer to your service agent for advice.



### 13. SPECIFICATIONS

**Power:**

Continuous sinewave power output<sup>1</sup> per channel, both channels driven:

-----DUAL CHANNEL-----		
SET LOAD SWITCH	LOAD $\Omega$	POWER W
4	8	385
4	4	650
2	2	570
2	1.5	680

-----BRIDGED-----		
SET LOAD SWITCH	LOAD $\Omega$	POWER W
8	16	770
8	8	1300
4	4	1140

**Distortion (THD):**

20Hz-20kHz, at any level 0.5dB below clip: < 0.1%, typ 0.01%

**Output DC offset voltage:**

<50mV, typ 5mV

**Noise:**

Relative to full output, 20Hz to 20kHz bandwidth: <-110dB

**Input:**

Electronically balanced. Optional internal transformer. 13k $\Omega$

**Input sensitivity.**

For full output power: -2 to +12 dBv. switchable

**Common mode rejection (CMR), 20Hz-2kHz:**

>100dB

2kHz-20kHz:

> 80dB

**Crosstalk, 20Hz to 20kHz, re. max output:**

> 90dB

**Slew rate limit (input filters removed):**

>80v/uS

**Damping Factor, 30 Hz to 1kHz:**

>1500

**Power Requirements per complete EPC-760:**

Under no signal conditions the EPC-760 takes less than 2 amp at 240v or under 4 amps on 120v mains supplies. The full drive current requirements are:

nominal 240 v continuous sinewave full power 8 amps  
average music at full power 4 amps

nominal 120v The current will be approximately double that noted for 240v above.

**Mounting dimensions from rack flanges: (w x ht x d):**

432 x 89 x 394mm  
19" x 3½" x 15½"

**Nett Weight (unboxed):**

36lbs/ 16.5 kg

**Gross Weight (includes carton):**

41lbs/ 18.5 kg

<sup>1</sup>FTC continuous rating, ie for a minimum of 5 minutes before thermal shut-off.

14. WARRANTY.

This unit is warranted by BSS AUDIO LTD to the original end-user purchaser against defects in workmanship and materials used in it's manufacture for a period of one year from date of shipment to the end-user.

Faults arising from misuse, unauthorised modifications or accidents are not covered by this warranty. No other warranty is expressed or implied.

Should the unit be faulty it should be sent, in it's original packaging, to the supplier or your local authorised BSS AUDIO LTD dealer with the shipping prepaid.

You should include a statement listing the faults found, and the serial number must be quoted in all correspondence relating to a claim.

**IMPORTANT:** We recommend you record your purchase information here for future reference.

Dealers Name:.....  
Address:.....  
Phone No:.....  
Invoice/receipt No/Date:.....  
Serial number of unit:.....

In keeping with our policy of continued improvement, BSS AUDIO LTD reserve the right to alter specifications without prior notice.

The EPC-760 was designed, developed and produced by BSS AUDIO LTD, Hertfordshire, England. Tel: 0727 45242. Fax: 0727 45277.

[V1.0 MAY 92]

